

HYPERTHERMIA OF CYLINDRICAL BIOTISSUE SAMPLES BY MICROWAVE ELECTROMAGNETIC RADIATION

Z. P. Shul'man, G. Ya. Slepyan,
T. L. Popkova, and A. A. Makhanyok

UDC 536.2.0172:612.014.424.5

Consideration is given to the interaction of plane and cylindrical electromagnetic waves with layered cylindrical biotissue. Space distributions of the power density of heat loss are calculated and analyzed. The influence of biotissue inhomogeneities (arteries, veins) on electromagnetic heating is evaluated. The results reported can be used for hyperthermia of biological objects in oncology.

1. Introduction. The microwave radiation-biotissue interaction is of considerable interest, in particular, in connection with hyperthermia problems in medicine [1-3]. The main characteristic of such interaction is the space power distribution of heat loss, which determines the initial condition for the problem on heat transfer in biotissue.

Real biotissue represents an inhomogeneous medium with a layered structure (skin, fat, muscles, bone, artery, and vein). In the known works it is modeled by a system consisting of plane layers. In the majority of papers, consideration is given to irradiation by plane waves. In [2], Michel et al. propose a microband irradiator for hyperthermia and discuss heating of a plane-layered medium by an inherent wave of a microband line. Such irradiators belong to high technologies and can be recommended for wide practical use.

However, the model of plane layers is not always adequate. In some cases, the curvature of the biotissue surface and the interfaces of its material parameters play an important role. A characteristic example, for instance, is the hyperthermia of extremities. Here, the cylindrical model of biotissue is more adequate, including the cylindrical model with a layered (stratified) structure. This brings up the problem on interaction of an electromagnetic field with cylindrical tissue with various modes of excitation. These aspects are the areas of concern in the present work.

In the rather general case, biotissue is modeled by a system consisting of six cylindrical layers differing in their complex dielectric permittivity.

2. Interaction of a Wave with a Layered Cylindrical Biotissue Sample. This model is the simplest in the entire class of models with cylindrical symmetry. As in the plane-layered model [3], only interference of waves proceeds in it, but these waves possess a more complicated spatial structure. The biotissue configuration under consideration is shown in Fig. 1. An incident wave possesses the E -polarization and is represented in the form $E^0 = y_0 H_0^{(1)}(kr)$, y_0 is the unit vector along the Y axis, $k = \omega/c$, $H_0^{(1)}$ is the Hankel function of the first kind (the time dependence is taken in the form $\exp(j\omega t)$), c is the sound velocity in vacuum. The case of H -polarization is easily considered in the same manner and does not lead to any new conclusions.

To solve the problem, we used the method of partial regions formed by interfaces of the material characteristics of a medium (Fig. 1). The electric field therein is represented in the form

$$E_y^{(1)} = A_1 J_0(kr \sqrt{\varepsilon_1}), \quad (1)$$

Academic Scientific Complex "A. V. Luikov Heat and Mass Transfer Institute of the National Academy of Sciences of Belarus," Minsk, Belarus. Institute for Nuclear Problems at the Belarusian State University, Minsk, Belarus. Translated from *Inzhenerno-Fizicheskii Zhurnal*, Vol. 71, No. 2, pp. 268-272, March-April, 1998. Original article submitted August 4, 1997.

$$E_y^{(i)} = A_i H_0^{(1)}(kr \sqrt{\varepsilon_i}) + B_i H_0^{(2)}(kr \sqrt{\varepsilon_i}), \quad (2)$$

$i = 2, 3, 4, 5, 6$; ε_i is the complex dielectric permittivity of the i th layer. The electric field outside the biotissue is

$$E_y^{(7)} = H_0^{(1)}(kr) + R H_0^{(2)}(kr), \quad (3)$$

$H_0^{(2)}$ is the Hankel function of the 2nd kind, J_0 is the Bessel function, A_i, B_i, R are the unknown constant coefficients, the superscript in parentheses at E_y denotes to the number of a partial region.

To determine the unknown quantities entering into (1)-(3), it is necessary to impose the conditions of continuity of the tangential components of electric and magnetic fields. As follows from the Maxwell conditions, in this case the boundary conditions for a magnetic field are reduced to continuity of the values $\partial E_y^{(i)}/\partial r$. As a result, we obtain the following matrix equation of the 12th order:

$$Sx = y, \quad (4)$$

where the vectors of unknown x and right-hand y parts (transposed) have the form

$$\begin{aligned} x^T &= (A_1, A_2, B_2, A_3, B_3, A_4, B_4, A_5, B_5, A_6, B_6, R), \\ y^T &= (0, 0, 0, 0, 0, 0, 0, 0, 0, 0, 0, M_1, M_2), \\ M_1 &= H_0^{(1)}(kR_6), \quad M_2 = H_1^{(1)}(kR_6). \end{aligned} \quad (5)$$

The matrix S has the following structure:

$$S = \begin{pmatrix} G_1 & F_3^{(1)} & F_4^{(1)} & 0 & 0 & 0 & 0 & 0 & 0 & 0 & 0 & 0 & 0 \\ G_2 & F_7^{(1)} & F_8^{(1)} & 0 & 0 & 0 & 0 & 0 & 0 & 0 & 0 & 0 & 0 \\ 0 & F_1^{(2)} & F_2^{(2)} & F_3^{(2)} & F_4^{(2)} & 0 & 0 & 0 & 0 & 0 & 0 & 0 & 0 \\ 0 & F_5^{(2)} & F_6^{(2)} & F_7^{(2)} & F_8^{(2)} & 0 & 0 & 0 & 0 & 0 & 0 & 0 & 0 \\ 0 & 0 & 0 & F_1^{(3)} & F_2^{(3)} & F_3^{(3)} & F_4^{(3)} & 0 & 0 & 0 & 0 & 0 & 0 \\ 0 & 0 & 0 & F_5^{(3)} & F_6^{(3)} & F_7^{(3)} & F_8^{(3)} & 0 & 0 & 0 & 0 & 0 & 0 \\ 0 & 0 & 0 & 0 & 0 & F_1^{(4)} & F_2^{(4)} & F_3^{(4)} & F_4^{(4)} & 0 & 0 & 0 & 0 \\ 0 & 0 & 0 & 0 & 0 & F_5^{(4)} & F_6^{(4)} & F_7^{(4)} & F_8^{(4)} & 0 & 0 & 0 & 0 \\ 0 & 0 & 0 & 0 & 0 & 0 & 0 & F_1^{(5)} & F_2^{(5)} & F_3^{(5)} & F_4^{(5)} & 0 & 0 \\ 0 & 0 & 0 & 0 & 0 & 0 & 0 & F_5^{(5)} & F_6^{(5)} & F_7^{(5)} & F_8^{(5)} & 0 & 0 \\ 0 & 0 & 0 & 0 & 0 & 0 & 0 & 0 & 0 & F_1^{(6)} & F_2^{(6)} & K_1 & 0 \\ 0 & 0 & 0 & 0 & 0 & 0 & 0 & 0 & 0 & F_5^{(6)} & F_6^{(6)} & K_2 & 0 \end{pmatrix}, \quad (6)$$

where $G_1 = J_0(k\sqrt{\varepsilon_1}R_1)$, $G_2 = \sqrt{\varepsilon_1}J_1(k\sqrt{\varepsilon_1}R_1)$, $F_1^{(i)} = H_0^{(1)}(k\sqrt{\varepsilon_i}R_i)$, $F_2^{(i)} = H_0^{(2)}(k\sqrt{\varepsilon_i}R_i)$, $F_3^{(i)} = -H_0^{(1)}(k\sqrt{\varepsilon_{i+1}}R_i)$, $F_4^{(i)} = -H_0^{(2)}(k\sqrt{\varepsilon_{i+1}}R_i)$, $F_5^{(i)} = \sqrt{\varepsilon_i}H_1^{(1)}(k\sqrt{\varepsilon_i}R_i)$, $F_6^{(i)} = \sqrt{\varepsilon_i}H_1^{(2)}(k\sqrt{\varepsilon_i}R_i)$, $F_7^{(i)} = -\sqrt{\varepsilon_{i+1}}H_1^{(1)}(k\sqrt{\varepsilon_{i+1}}R_i)$, $F_8^{(i)} = -\sqrt{\varepsilon_{i+1}}H_1^{(2)}(k\sqrt{\varepsilon_{i+1}}R_i)$, $K_1 = -H_0^{(2)}(kR_6)$, $K_2 = -H_1^{(2)}(kR_6)$.

System (4) was solved on a computer for various biotissue samples. Calculation results and their discussion are given below.

3. Interaction of a Plane Wave with a Layered Cylindrical Biotissue Sample. Consideration is given to the same configuration as in the previous section (see Fig. 1) but an incident wave has the form $E^0 = y_0 \exp(-jkz) = y_0 \exp(-jkr \cos \varphi)$. The physics of the interaction becomes considerably more complicated as compared to Sec.

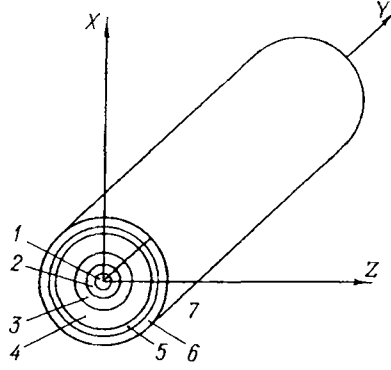

Fig. 1. Configuration of the biotissue sample: 1-6) numbers of partial regions; 7) biotissue environment.

2, namely, diffraction of waves occurs. Let us represent the incident wave in the form of expansion in cylindrical waves [4]:

$$E^0 = y_0 \sum_{m=-\infty}^{\infty} J_m(kr) \exp(-jm\varphi). \quad (7)$$

To solve the problem, we generalize the method adopted in the previous section. Instead of equalities (1)-(3), we use the expansions

$$E_y^{(1)} = \sum_{m=-\infty}^{\infty} A_{1m} J_m(kr \sqrt{\varepsilon_1}) \exp(-jm\varphi), \quad (8)$$

$$E_y^{(i)} = \sum_{m=-\infty}^{\infty} [A_{im} H_m^{(1)}(kr \sqrt{\varepsilon_i}) + B_{im} H_m^{(2)}(kr \sqrt{\varepsilon_i})] \exp(-jm\varphi), \quad i = 2, 3, 4, 5, 6, \quad (9)$$

$$E_y^{(7)} = \sum_{m=-\infty}^{\infty} [J_m(kr) + R_m H_m^{(2)}(kr)] \exp(-jm\varphi), \quad (10)$$

Imposing boundary conditions as in Sec. 2, we obtain an infinite set of finite systems of linear algebraic equations for the unknown coefficients A_{im} , B_{im} , R_m :

$$S_m x_m = y_m. \quad (11)$$

The structure of the vectors x_m , y_m and the matrix S_m is fully identical to (5), (6) (with the only difference that each element acquires the additional subscript m). The matrix elements are determined by the following equalities:

$$G_{1m} = J_m(k \sqrt{\varepsilon_1} R_1), \quad G_{2m} = \sqrt{\varepsilon_1} J_m(k \sqrt{\varepsilon_1} R_1), \quad F_{1m}^{(i)} = H_m^{(1)}(k \sqrt{\varepsilon_i} R_i), \quad F_{2m}^{(i)} = H_m^{(2)}(k \sqrt{\varepsilon_i} R_i),$$

$$F_{3m}^{(i)} = -H_m^{(1)}(k \sqrt{\varepsilon_{i+1}} R_i), \quad F_{4m}^{(i)} = -H_m^{(2)}(k \sqrt{\varepsilon_{i+1}} R_i), \quad F_{5m}^{(i)} = \sqrt{\varepsilon_i} H_m^{(1)}(k \sqrt{\varepsilon_i} R_i),$$

$$F_{6m}^{(i)} = \sqrt{\varepsilon_i} H_m^{(2)'}(k \sqrt{\varepsilon_i} R_i), \quad F_{7m}^{(i)} = -\sqrt{\varepsilon_{i+1}} H_m^{(1)'}(k \sqrt{\varepsilon_{i+1}} R_i), \quad F_{8m}^{(i)} = -\sqrt{\varepsilon_{i+1}} H_m^{(2)'}(k \sqrt{\varepsilon_{i+1}} R_i),$$

$$K_{1m} = -H_m^{(2)}(kR_6), \quad K_{2m} = -H_m^{(2)'}(kR_6)$$

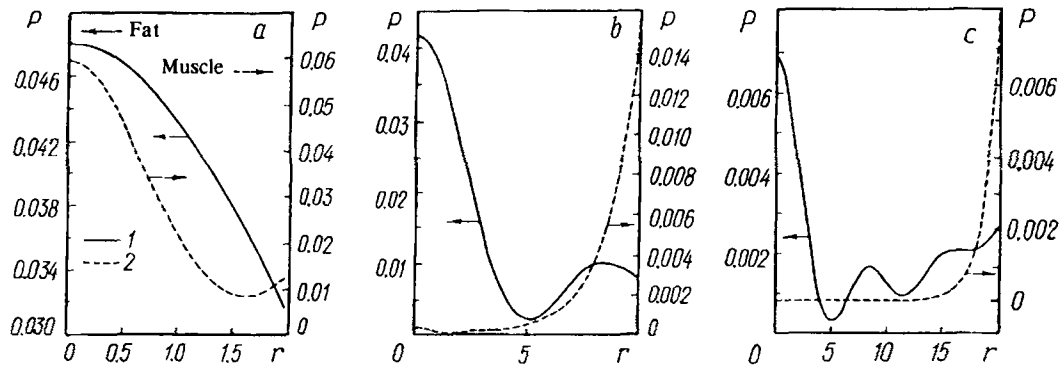

Fig. 2. Power-density distribution of heat losses of the electromagnetic energy in cylindrical biotissue samples [1) fat, 2) muscle] with a radius of 2 (a), 10) (b), and 20 cm (c). P , W/m^3 ; r , cm.

(a prime indicates the derivative of the function with respect to the overall argument). The free terms are determined by the equalities $M_{1m} = J_m(kR_6)$, $M_{2m} = -J'_m(kR_6)$.

Series (8)-(10) are convergent and can be approximated by end sums. Therefore, in practice it is sufficient to obtain a solution of the end number of systems (11). The required order of approximation considerably depends on the biotissue dimensions and its material parameters.

4. Results and Discussion. A physical characteristic of the field that is of basic interest for hyperthermia is the space power distribution of heat loss. We have calculated the power density of heat loss expressed by the relation

$$P = \frac{\epsilon_0}{2} \text{Im } \epsilon(r) |E_y|^2, \quad (12)$$

where $\epsilon(r)$ is the piecewise-constant distribution of the complex dielectric permittivity [$\epsilon(r) = \epsilon_i$ in the i th partial region, $\epsilon_7(r) = 1$ is the dielectric permittivity of vacuum (air)], $\epsilon_0 = 8.854 \cdot 10^{-12}$ F/m.

Figure 2 shows $P(r)$ for cylindrical samples of muscle and fat tissue of different radii in the case of irradiation by a cylindrical wave at a frequency of $f = 915$ MHz (in accordance with [1], $\text{Re } \epsilon = 51$, $\text{Im } \epsilon = 31$ are adopted for the muscle and $\text{Re } \epsilon = 5.6$, $\text{Im } \epsilon = 2.0$ – for the fat). As the calculated curves show, $P(r)$ for the fat sample is a strongly nonuniform oscillating function and the degree of nonuniformity is considerably higher than in the corresponding two-dimensional case. At some radius values a local maximum appears on the cylinder axis (at $r = 0$).

The qualitative character of $P(r)$ for the fat sample allows us to conclude that $P(r)$ can be rather efficiently controlled with the aid of semitransparent external screens (this idea is suggested in [3] for plane biotissue samples). For synthesis of such a screen it is necessary in each particular case to use the current methods of computational electrodynamics [5-8].

In the case of muscle tissue, $P(r)$ displays a considerably more pronounced monotonic dependence. For a biotissue sample of large radius, only the surface layer is effectively heated through, while in the case of small radii the qualitative picture of $P(r)$ changes, i.e., the central part of the sample is effectively heated. This effect is of importance for local hyperthermia.

In the same manner, the idea of [2] on application of microband irradiators can be modified. For cylindrical heated objects, use can be made of cylindrical band lines and heating can be accomplished by their intrinsic waves. A procedure of electrodynamic calculation of such lines is given, e.g., in [7].

5. Influence of Biotissue Microinhomogeneities on Absorption of Electromagnetic Waves. In the foregoing, we have considered the process of absorption of electromagnetic waves by piecewise-homogeneous cylindrical layers. Real biotissue is always inhomogeneous: for instance, blood vessels (arteries, veins) pass through muscle tissue. As a result of absorption of electromagnetic waves by them, blood undergoes heating and carries away the heat of

the heated region. Therefore, it is reasonable to introduce a correction for heating of blood vessels in calculations of the absorbed power.

Arteries and veins in hyperthermia problems can be modeled by thin circular cylinders whose dielectric parameters differ from those of the ideal muscle tissue. In this connection, the inhomogeneous muscle tissue can be considered as a dielectric composite and characterized by the effective dielectric permeability ϵ_{ef} . To calculate the latter, the general methods of the electrodynamics of composite media can be employed, which have recently been extensively developed [9-12].

In the present work, we have adopted the simplest model of a composite: cylinders are identical, straight, parallel to each other, and directed along the Y axis. Then, according to [10], within the framework of the Maxwell–Hartnett model we can write

$$\epsilon_{ef} = \epsilon_m \left(1 + 2f \frac{\epsilon_b - \epsilon_m}{\epsilon_b + \epsilon_m} \right), \quad (13)$$

where ϵ_m , ϵ_b is the complex dielectric permittivity of the homogeneous muscle tissue and blood, respectively; f is the specific density of blood vessels per unit volume.

The absorbed power will be evaluated in an approximation linear with respect to the loss tangent of the dielectric. Assuming that $\epsilon_m = \epsilon'_m + j\epsilon''_m$ and $\epsilon_b = \epsilon'_b + j\epsilon''_b$, we obtain $\epsilon_{ef} = \epsilon'_{ef} + j\epsilon''_{ef}$ from (13), where

$$\epsilon''_{ef} \approx \epsilon''_m \left(1 + 2f \frac{\epsilon_b'^2 - 2\epsilon'_b \epsilon'_m - \epsilon_m'^2}{\epsilon_b'^2 + 2\epsilon'_b \epsilon'_m + \epsilon_m'^2} \right) + \epsilon_b'' \frac{4f \epsilon_m'^2}{(\epsilon_b' + \epsilon_m')^2}, \quad (14)$$

Thus, for the effective absorbed power we obtain $P_{ef} = P_m(1 + \zeta)$, where P_m is the power absorbed directly by the muscle tissue and

$$\zeta \approx \frac{4f \epsilon_m'^2}{(\epsilon_b' + \epsilon_m')^2} \frac{\epsilon_b''}{\epsilon_m''}. \quad (15)$$

For P_m we have

$$P_m \approx P_{ef} (1 - \zeta). \quad (16)$$

The coefficient ζ in formula (16) describes a decrease in the efficiently absorbed power due to heating of the blood in the blood vessels. Numerical estimates show that this coefficient is fairly small for the typical parameters of biotissues.

The authors thank the Fundamental Research Foundation of the Republic of Belarus for financial support of the work on a contract (B94-009) basis.

REFERENCES

1. A. Guy, J. Lehmann, and J. Stonebridge, *IEEE*, **62**, No. 1, 66-93 (1974).
2. C. Michel, P.-Y. Cresson, L. Dubois, M. Chive, and J. Probetich, *Microwave Opt. Tech. Lett.*, **12**, No. 3, 123-128 (1966).
3. Z. P. Shulman and G. Ya. Slepian, *Inzh.-Fiz. Zh.* (in press, 1997).
4. V. T. Erofeenko, *The Theorems of Addition* [in Russian], Minsk (1989).
5. A. S. Ilyinsky, G. Ya. Slepian, and A. Ya. Slepian, *IEE Electromagnetic Wave Series* (P. Peregrinos, ed.), Vol. 36 (1993).
6. A. S. Il'inskii and G. Ya. Slepian, *Oscillations and Waves in Electrodynamical Systems with Losses* [in Russian], Minsk (1983).
7. V. P. Shestopalov, *Spectral Theory and Excitation of Open Structures* [in Russian], Kiev (1987).

8. E. V. Zakharov and Yu. V. Pimenov, Numerical Analysis of Radio-Wave Diffraction [in Russian], Moscow (1982).
9. G. DulMasc and G. F. Dell'Antonio (eds.), Composite Media and Homogenization Theory, The Proceedings of the ICTP Workshop Held at Trieste, Italy in January 1990, Boston (1991).
10. O. Levy, J. Appl. Phys., 77(4), 1696-1700 (1995).
11. Electrical Transport and Optical Properties of Inhomogeneous Media, Proceedings of the I TOPIM4 Int. Conf. Moscow. St. Petersburg, July 1966 (A. M. Dukhne, A. N. Lagarkov, and A. N. Sarychev, eds.), Moscow (1996).
12. F. G. Bass and I. M. Fuks, Wave Scattering by Statistically Rough Surfaces [in Russian], Moscow (1972).